

Assembly Instructions

1. Fit item 3 to item 1
2. Fit item 4 to item 1
3. Fit 2 off item 2 to item 1
It is important that the external slot feature in item 2 aligns with the tapped hole in item 1
4. Fit 2 off item 5
It is important that when tightened item 5 its top edge does not sit above face A

	F	G	H
	PART NUMBER	DESCRIPTION	QTY.
1	P9999-12101	Piston	1
2	P9999-12102	Piston Bearing	2
3	O-Ring_42-4	42mm ID X 4mm Cross Section O-Ring	1
4	M6-NIP	M6 Grease Nipple	1
5	M4-10-SKT SET	M4 X 10 Socket Set	2

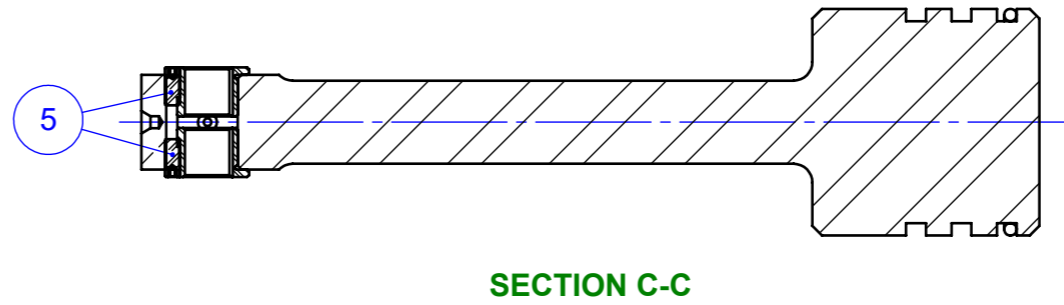
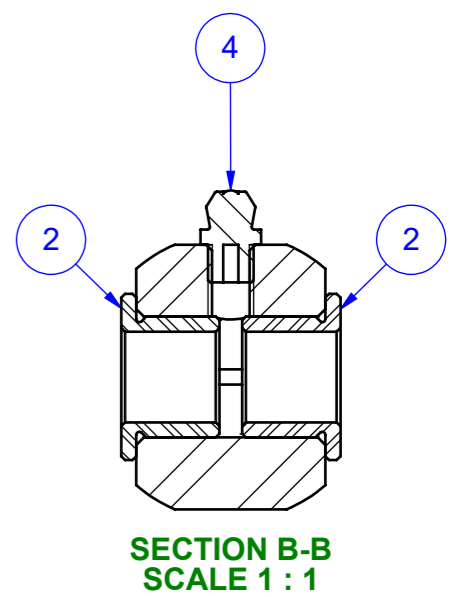
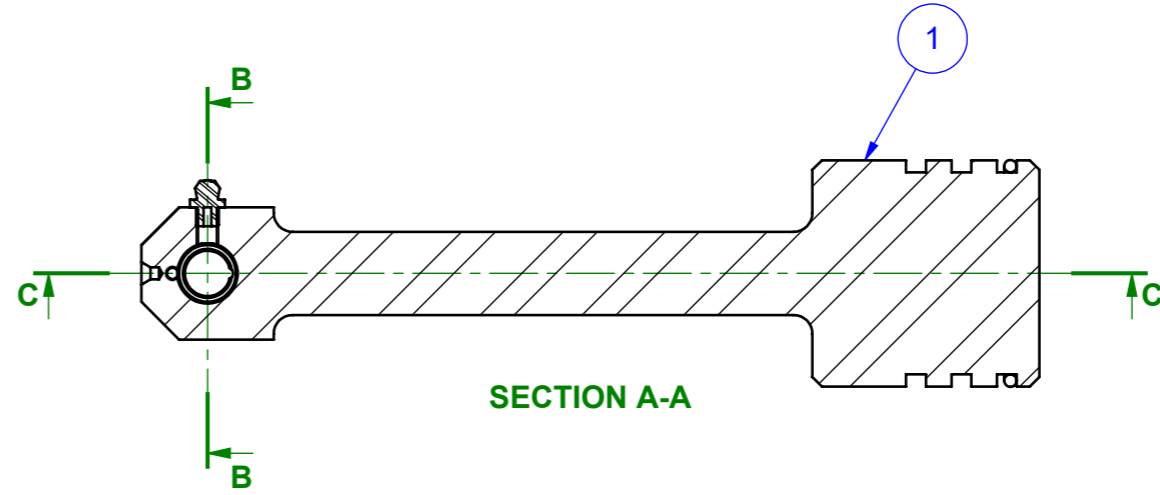
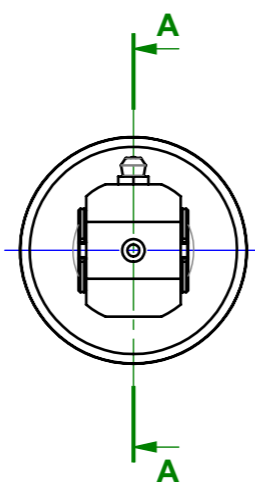

See exploded Isometric on Sheet 2

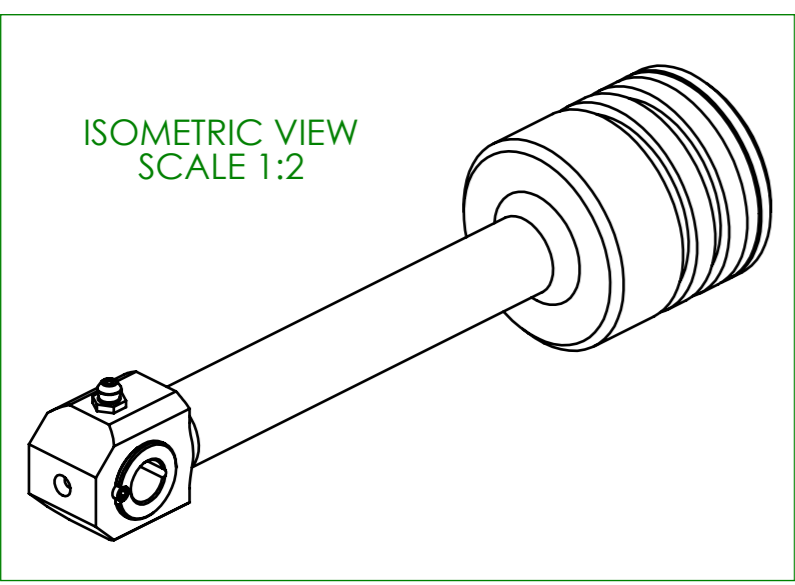

Customer Confidential

White Horse CAD Ltd Design Rights 2019 Tel: +44 (0) 1373 801 803 www.whitehorsecad.com		Material: See Part Drawings	System: Wobble Engine	Drawing Number	Scale	Rev	Date	Rev	Drawn	Notes
		Material Standard: (If Required)	Item: Piston Assembly	P9999-12001	1:2	1	19-Oct-2019	1	WHC	
		Finish: N/A	THIRD ANGLE PROJECTION	Unspecified Dimensions X ± 1mm X.X ± 0.3mm X.XX ± 0.1mm	All Dimensions in mm DO NOT SCALE	Paper Size	Sheet			
					A3	1 of 2				

Assembly Instructions

1. Fit item (3) to item (1)
2. Fit item (4) to item (1)
3. Fit 2 off item (2) to item (1)
It is important that the external slot feature in item (2) aligns with the tapped hole in item (1)
4. Fit 2 off item (5)
It is important that when tightened item (5) its top edge does not sit above face **A**

	F	G	H
	PART NUMBER	DESCRIPTION	QTY.
1	P9999-12101	Piston	1
2	P9999-12102	Piston Bearing	2
3	O-Ring_42-4	42mm ID X 4mm Cross Section O-Ring	1
4	M6-NIP	M6 Grease Nipple	1
5	M4-10-SKT SET	M4 X 10 Socket Set	2

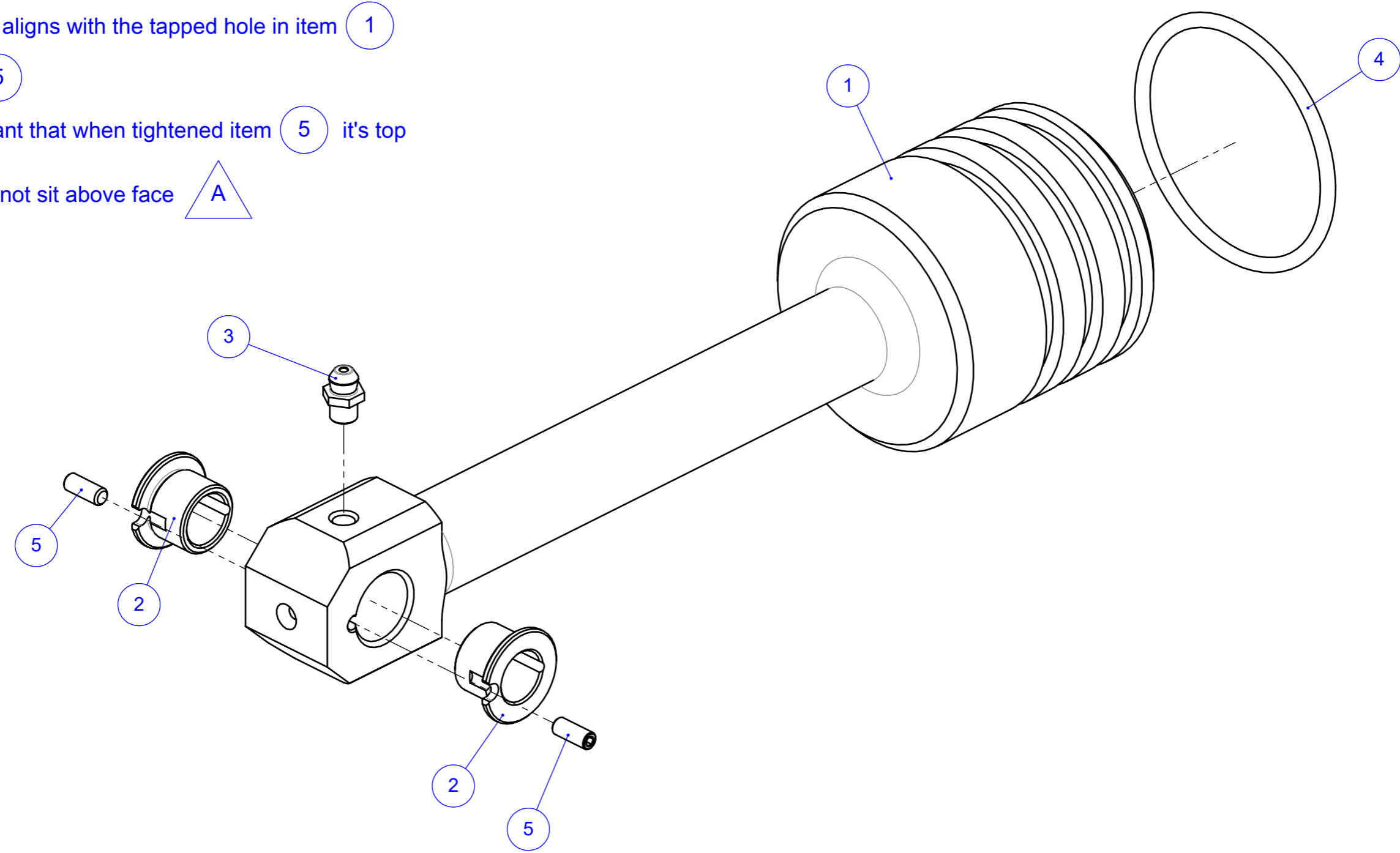

Customer Confidential

White Horse CAD Ltd Design Rights 2019 Tel: +44 (0) 1373 801 803 www.whitehorsecad.com		Material: See Part Drawings	System: Wobble Engine	Drawing Number	Scale	Rev	Date	Rev	Drawn	Notes
		Material Standard: (If Required)	Item: Piston Assembly	P9999-12001	1:1	1	19-Oct-2019	1	WHC	
		Finish: N/A	THIRD ANGLE PROJECTION	Unspecified Dimensions X ± 1mm X.X ± 0.3mm X.XX ± 0.1mm	All Dimensions in mm DO NOT SCALE	Paper Size	Sheet			
					A3	2 of 2				